

Standard executions		
Version	Symbol	Type
Double acting, magnetic self lubricating bushings		GSB
Double acting, magnetic spherical bushings		GSS



Series of twin-rod cylinders magnetic as standard. This cylinder is of two-axle mode with double thrust force and smooth and precise operation. A one piece body is provided with grooves allowing the mounting of the magnetic reed switch without further brackets; this makes the magnetic sensor not protrude outside the body itself. The bottom plates are provided with elastic cushionings.

For the magnetic reed switches type ASV see from page 1.110.1.

Options	Suffix
Special on request	/ S

How to order: 20/30 GSB

20	/	30	GSB	
Bore	/	Stroke	Type	Option

Technical data						
Fluid	Compressed filtered air with or without lubrication. Lubrication, if started, must be continued.					
Bore	Ø 6	Ø 10	Ø 16	Ø 20	Ø 25	Ø 32
Pressure range	1.5 ÷ 7 bar		1 ÷ 7 bar		0.5 ÷ 7 bar	
Speed range	30÷300 mm/sec.			30÷500 mm/sec.		
Adjustable stroke	0 ÷ -5 mm					
Temperature range	- 10 °C ÷ + 60°C					

Bore (mm)	Standard stroke GSB	Standard stroke GSS
6	10, 20, 30, 40, 50	10, 20, 30, 40, 50
10	10, 15, 20, 25, 30, 35, 40, 45, 50	10, 15, 20, 25, 30, 35, 40, 45, 50
16	10, 15, 20, 25, 30, 35, 40, 45, 50, 60, 70, 75, 80, 90, 100, 125, 150	10, 15, 20, 25, 30, 35, 40, 45, 50, 60, 70, 75, 80, 90, 100, 125, 150
20	10, 15, 20, 25, 30, 35, 40, 45, 50, 60, 70, 75, 80, 90, 100, 125, 150	10, 15, 20, 25, 30, 35, 40, 45, 50, 60, 70, 75, 80, 90, 100, 125, 150
25	10, 15, 20, 25, 30, 35, 40, 45, 50, 60, 70, 75, 80, 90, 100, 125, 150	10, 15, 20, 25, 30, 35, 40, 45, 50, 60, 70, 75, 80, 90, 100, 125, 150
32	10, 15, 20, 25, 30, 35, 40, 45, 50, 60, 70, 75, 80, 90, 100, 125, 150	10, 15, 20, 25, 30, 35, 40, 45, 50, 60, 70, 75, 80, 90, 100, 125, 150

# Twin rod compact guided cylinders

Bores from 6 to 32 mm

Materials



Type: **GSB - GSS**  
(Bore  $\varnothing 12 \div \varnothing 25$ )

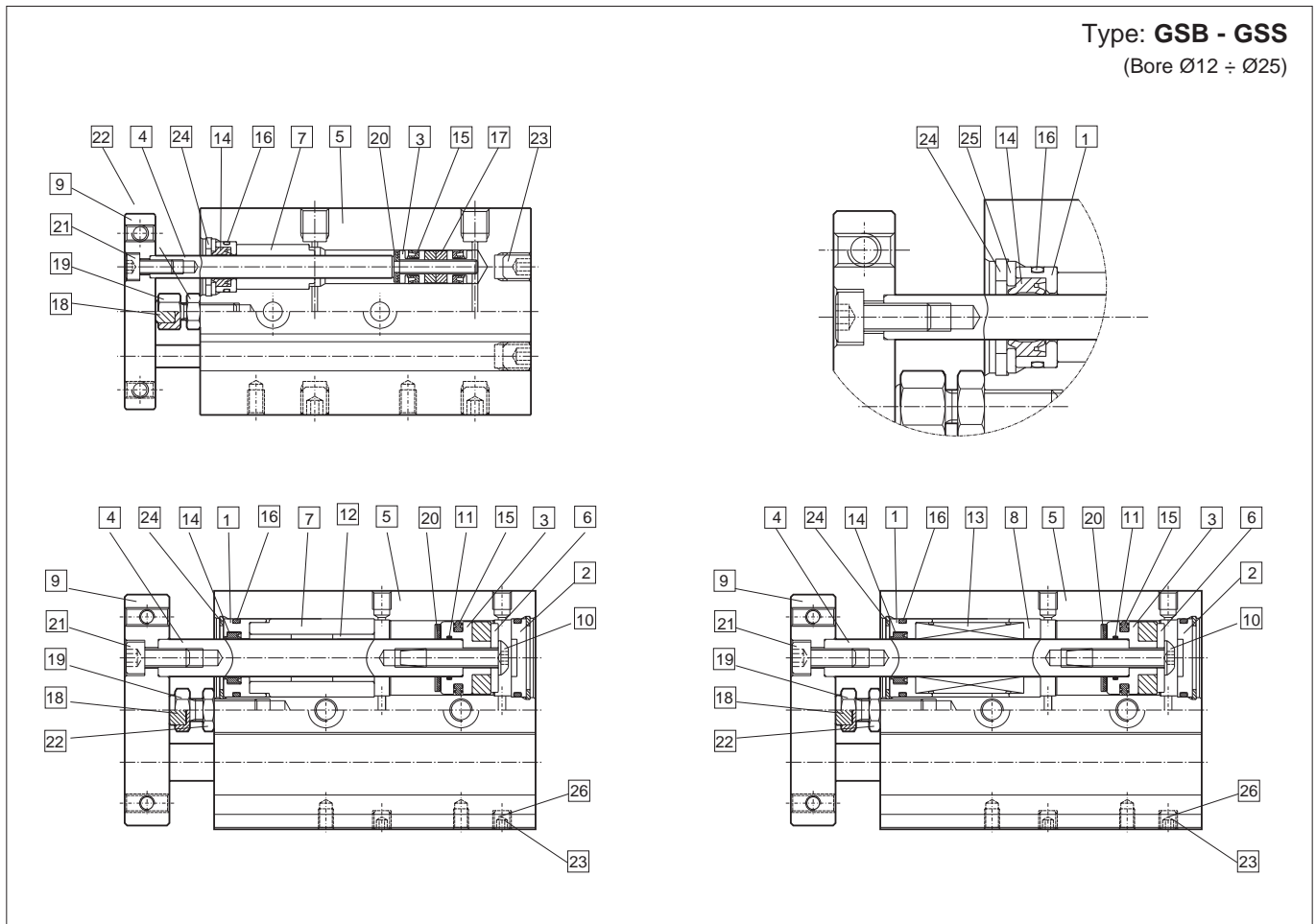

Materials					
1	Rod cover	Hard anodised aluminium alloy	14	Rod packing	PU
2	Head cover	Hard anodised aluminium alloy	15	Piston packing	Nitrile rubber NBR
3	Piston	Brass ( $\varnothing 6$ ) - Aluminium alloy ( $\varnothing 10 \div \varnothing 32$ )	16	Cylinder gasket	Nitrile rubber NBR
4	Piston rod	Stainless steel (GSB $\varnothing 6 \div \varnothing 10$ ) Carbon steel ( GSB $\varnothing 16 \div \varnothing 32$ ) Special steel (GSS)	17	Magnet	Magnetic material
5	Cylinder tube	Hard anodised aluminium alloy	18	Rubber pillar	Nitrile rubber NBR
6	Magnet holder	Stainless steel	19	Adjusting screw	Stainless steel
7	Bearing holder	Brass ( $\varnothing 6$ ) - Aluminium alloy ( $\varnothing 10 \div \varnothing 32$ )	20	Rubber lining	Nitrile rubber NBR
8	Bearing holder	Aluminium alloy ( $\varnothing 10 \div \varnothing 32$ )	21	Screw	Carbon steel nickel plating
9	Guide plate	Hard anodised aluminium alloy	22	Lock nut	Carbon steel nickel plating
10	Nut	Carbon steel nickel plating	23	Set screw	Carbon steel
11	O-ring	Nitrile rubber NBR	24	Retaining ring	Carbon steel nickel plating
12	Oilless bearing	Oil-impregnated sintered alloy	25	Steel pad	Stainless steel
13	Linear bearing	Special steel	26	Port gasket	Nitrile rubber NBR

# Twin rod compact guided cylinders

## Bores from 6 to 32 mm

### Standard dimensions



1

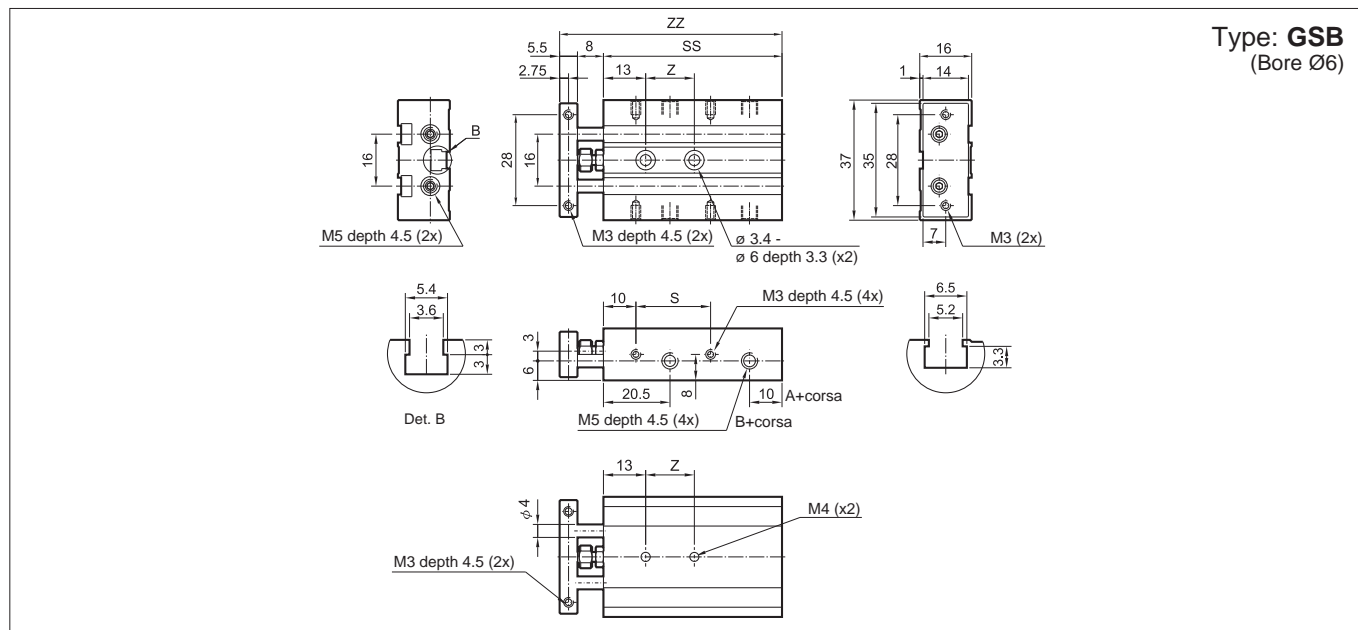

Ø mm	Stroke = 10				Stroke = 20				Stroke = 30				Stroke = 40				Stroke = 50			
	S	Z	SS	ZZ	S	Z	SS	ZZ	S	Z	SS	ZZ	S	Z	SS	ZZ	S	Z	SS	ZZ
6	23	15	55	68,5	33	20	65	78,5	43	25	75	88,5	53	30	85	98,5	63	35	95	108,5

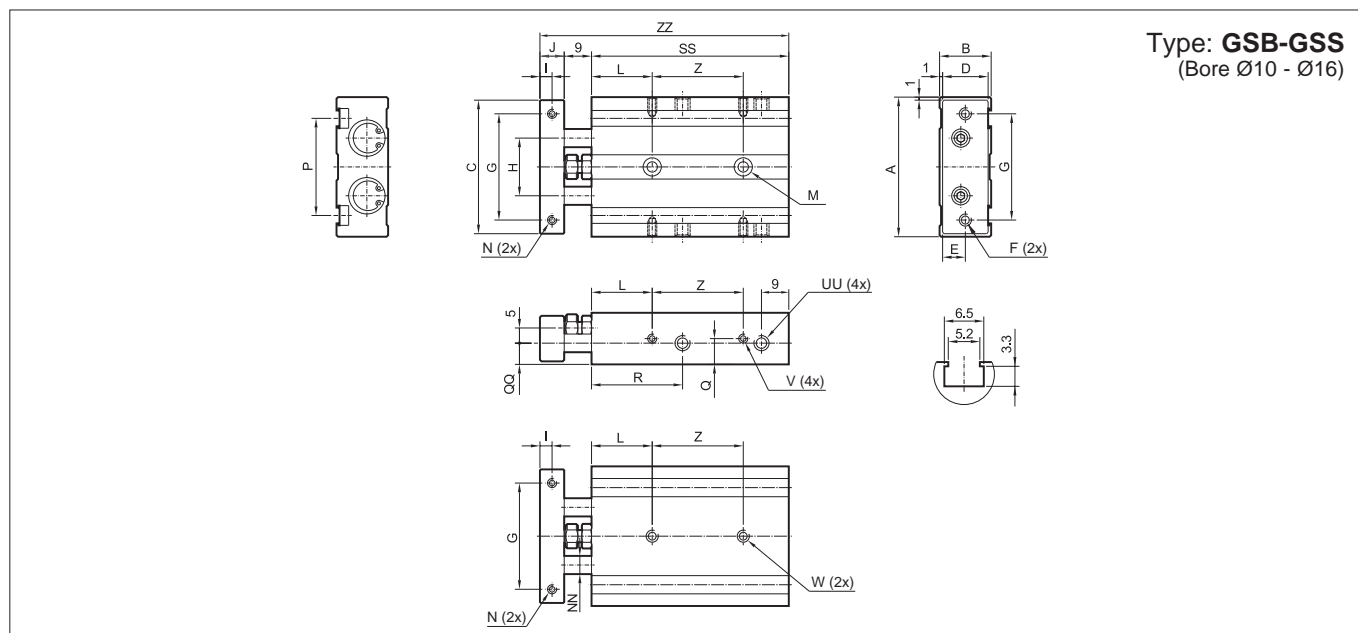

Ø mm	A	B	C	D	E	F	G	H	I	J	L	M	N	NN	P	Q	QQ	R	W	V
10	46	17	44	15	7.5	M4	35	19	4	8	20	Ø 3.4 - Ø 6 depth 3.3	M3 depth 5	Ø 6	32	8.5	7	30	M4 depth 8	M3 depth 4.5
16	58	20	56	18	9	M5	45	24	5	10	30	Ø 4.3 - Ø 8 depth 4.4	M4 depth 6	Ø 8	47	10	10	36	M5 depth 9	M4 depth 5

Ø mm	UU	Stroke = 10			Stroke = 15			Stroke = 20			Stroke = 25			Stroke = 30			Stroke = 35			Stroke = 40			Stroke = 45			Stroke = 50		
		SS	Z	ZZ	SS	Z	ZZ	SS	Z	ZZ	SS	Z	ZZ	SS	Z	ZZ	SS	Z	ZZ	SS	Z	ZZ	SS	Z	ZZ	SS	Z	ZZ
10	M5 depth 4.5	65	30	82	70	30	87	75	30	92	80	30	97	85	40	102	90	40	107	95	40	112	100	40	117	105	40	122
16	M5 depth 5.5	70	25	89	75	25	94	80	25	99	85	25	104	90	35	109	95	35	114	100	35	119	105	35	124	110	35	129

Ø mm	Stroke = 60			Stroke = 70			Stroke = 75			Stroke = 80			Stroke = 90			Stroke = 100			Stroke = 125			Stroke = 150		
	SS	Z	ZZ	SS	Z	ZZ	SS	Z	ZZ	SS	Z	ZZ	SS	Z	ZZ	SS	Z	ZZ	SS	Z	ZZ	SS	Z	ZZ
10	-	-	-	-	-	-	-	-	-	-	-	-	-	-	-	-	-	-	-	-	-	-	-	-
16	120	45	139	130	45	149	135	45	154	140	45	159	150	55	169	160	55	179	185	80	204	210	80	229

# Twin rod compact guided cylinders

## Bores from 6 to 32 mm

### Standard dimensions



Type: **GSB - GSS**  
(Bore  $\varnothing 20 - \varnothing 32$ )

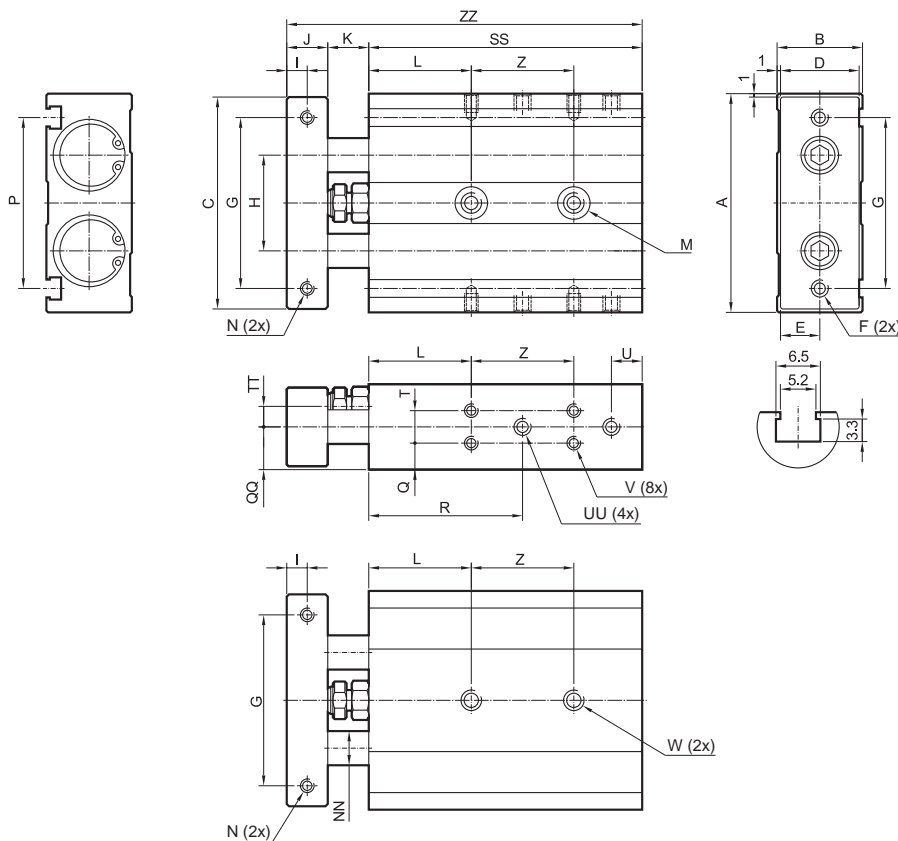

$\varnothing$ mm	A	B	C	D	E	F	G	H	I	J	K	L	M	N	NN ( $\varnothing$ )	P	Q	QQ	R	T	TT	U
20	64	25	62	23	11.5	M5	50	28	6	12	12	30	$\varnothing 5.5 - \varnothing 9.5$ depth 5.4	M4 depth 7.5dp	10	50	7.75	12.5	45	9.5	6	9
25	80	30	78	28	14	M6	60	35	6	12	12	30	$\varnothing 6.8 - \varnothing 11$ depth 6.3	M5 depth 7.5dp	12	60	8.5	15	44.5	13	9	10
32	98	38	96	36	18	M6	75	44	8	16	14	30	$\varnothing 6.8 - \varnothing 11$ depth 6.3	M5 depth 10dp	16	74	9	19	52.5	20	11	12

$\varnothing$ mm	UU	V	W	Stroke = 10			Stroke = 15			Stroke = 20			Stroke = 25			Stroke = 30			Stroke = 35			Stroke = 40		
				SS	Z	ZZ	SS	Z	ZZ	SS	Z	ZZ	SS	Z	ZZ	SS	Z	ZZ	SS	Z	ZZ	SS	Z	ZZ
20	M5	M4 depth 5.5	M6 depth 10dp	80	30	104	85	30	109	90	30	114	95	30	119	100	40	124	105	40	129	110	40	134
25	1/8 gas	M5 depth 7.5	M8 depth 16dp	82	30	106	87	30	111	92	30	116	97	30	121	102	40	126	107	40	131	112	40	136
32	1/8 gas	M5 depth 7.5	M8 depth 16dp	92	40	122	97	40	127	102	40	132	107	40	137	112	50	142	117	50	147	122	50	152

$\varnothing$ mm	Stroke = 45			Stroke = 50			Stroke = 60			Stroke = 70			Stroke = 75			Stroke = 80			Stroke = 90			Stroke = 100			Stroke = 125			Stroke = 150		
	SS	Z	ZZ	SS	Z	ZZ	SS	Z	ZZ	SS	Z	ZZ	SS	Z	ZZ	SS	Z	ZZ	SS	Z	ZZ	SS	Z	ZZ	SS	Z	ZZ	SS	Z	ZZ
20	115	40	139	120	40	144	130	60	154	140	60	164	145	60	169	150	60	174	160	60	184	170	60	194	195	85	219	220	85	244
25	117	40	141	122	40	146	132	60	156	142	60	166	147	60	171	152	60	176	162	60	186	172	60	196	197	85	221	222	85	246
32	127	50	157	132	50	162	142	70	172	152	70	182	157	70	187	162	70	192	172	70	202	182	70	212	207	95	237	232	95	262