

Standard executions		
Version	Symbol	Type
Double acting		RED
Double acting magnetic		REDM

II 2Gc IIC T5
II 2Dc T100°C

On request, they can be supplied according to 2014/34/EU - ATEX

Options	Suffix
Through rod	P
Seals FKM -20°C ÷ +150°C	V
Special versions on request	/S

The options can be combined (when this is possible)



Series of cylinders not conforming to standards
 The heads are connected with the body through thread; this guarantees perfect tightening.
 The cushionings are in nitrile rubber to relieve the impact of the piston.
 The standard cylinders are provided with rod nut.
 One or more magnetic reed switches can be applied to the magnetic type.
 For the magnetic reed switches type ASV see from page 1.110.1.
 For mounting accessories see from page 1.11.3.
 For rod accessories see from page 1.85.5.

How to order: 40 / 50 REDMP

40	/	50	REDM	P
Bore	/	Stroke	Type	Option

Technical data	
Fluid	Compressed filtered air with or without lubrication. Lubrication, if started, must be continued.
Pressure	max 10 bar
Temperature range	-30°C ÷ +80°C (standard) -20°C ÷ +150°C (V)
Materials	Heads: Anodised aluminium Tube: Anodised aluminium Rod: Chrome-plated steel C45 Seals: Polyurethane - NBR

Bore (mm)	Standard strokes (mm)	Max stroke (mm)
32	25, 50, 80,100, 125, 160, 200, 250, 320, 400, 500	1000
40		
50		

See page 1.1.3 to calculate the double acting cylinder force.
 Seal kits not available for these cylinders.

Type: RED-REDM

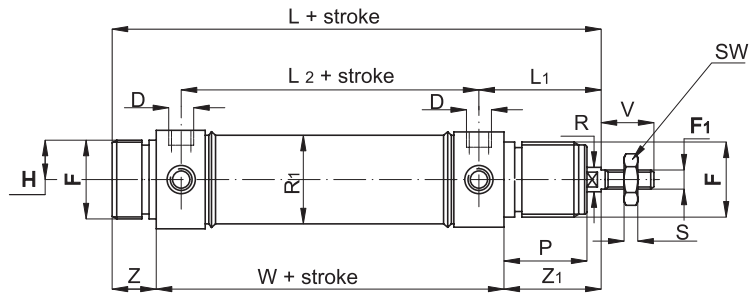

Ø mm	V	F	P	D	F ₁	R	L ₂	Z	Z ₁	W	L ₁	L	R ₁	H	S	SW
32	20	M 30x1,5	30	1/8"	M10x1,5	12	78	14	38	96	47	148	36	17,5	6	17
40	24	M 38x1,5	35	1/4"	M12x1,75	16	89	16	45	113	57	174	45	21	7	19
50	32	M 45x1,5	38	1/4"	M16x2	20	96	18	50	120	62	188	55	26,5	8	24

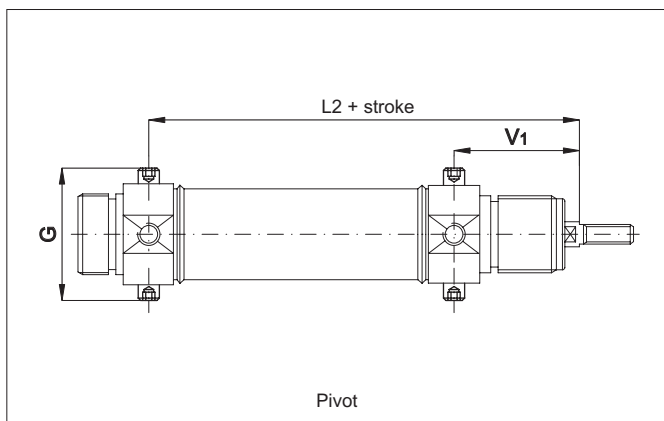
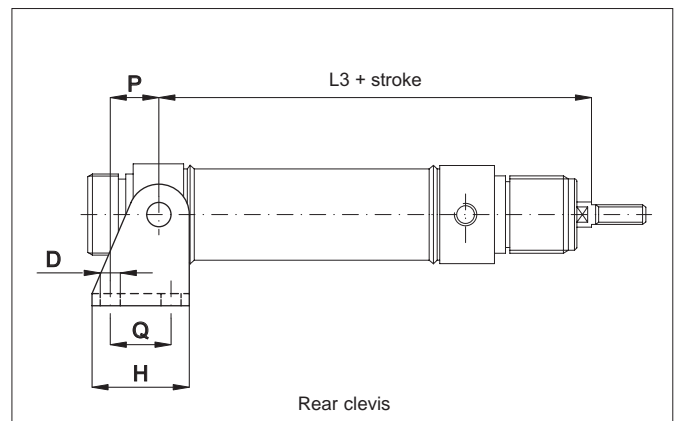
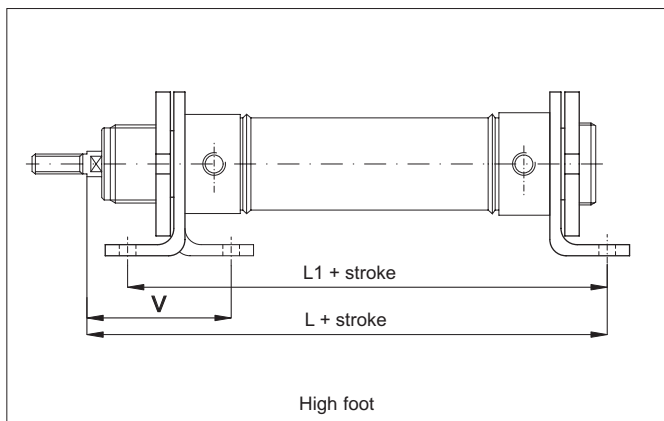

Ø mm	L	L ₁	L ₂	L ₃	V	V ₁	P	H	Q	G	D
32	148	124	125	125	48	47	20	40	24	51	7
40	178	153	146	146	60	57	27	50	30	61	9
50	190	160	158	158	64	62	30	54	34	75	9

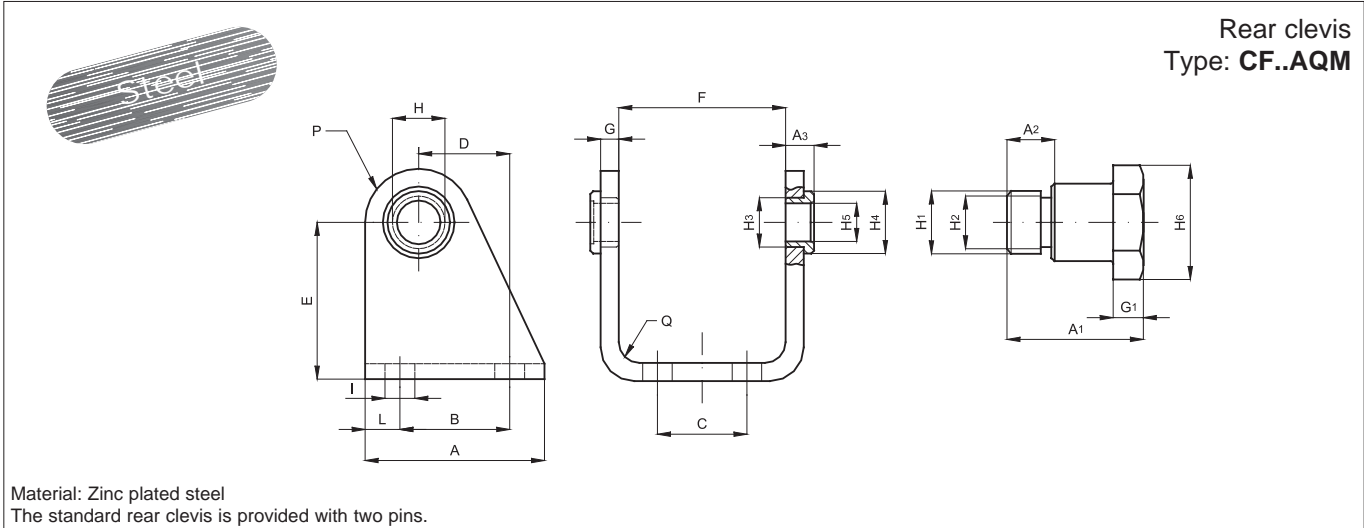

Code	Item	Ø mm	A	A ₁	A ₂	A ₃	B	C	D	E	F	G	G ₁	H	H ₁	H ₂	H ₃	H ₄	H ₅	H ₆	I	L	P	Q
040058	CF32AQM	32	40	18	6	6	24	20	20	35	38,1	4	4	12	10	M8x1	12	15	10	13	7	8	12	4
040059	CF40AQM	40	50	21,6	7	7	30	28	27	40	46,1	5	5	15	12	M10x1	15	20	12	17	9	10	13	5
040060	CF50AQM	50	54	26,4	9	8,5	34	36	30	45	57,1	6	6	18	14	M12x1,5	18	23	14	19	9	10	14	6

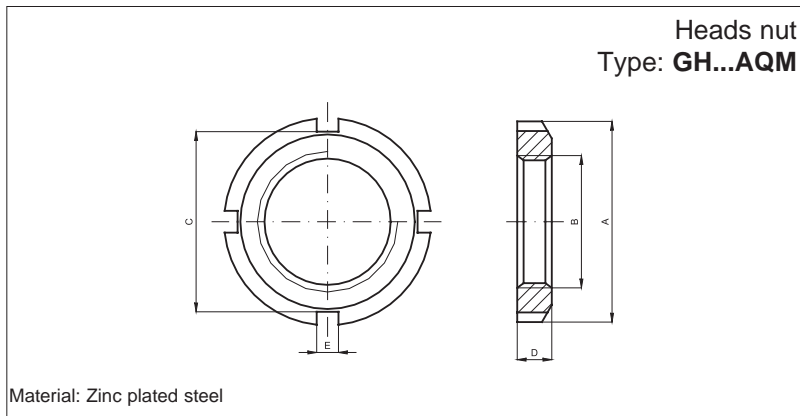

Code	Item	Ø mm	A	B	C	D	E
040066	GH32AQM	32	Ø 45	M30x1,5	40	7	5
040067	GH40AQM	40	Ø 50	M38x1,5	46	8	5
040068	GH50/63AQM	50	Ø 58	M45x1,5	53	9	6

High foot/Flange
Type: **P..AQM**

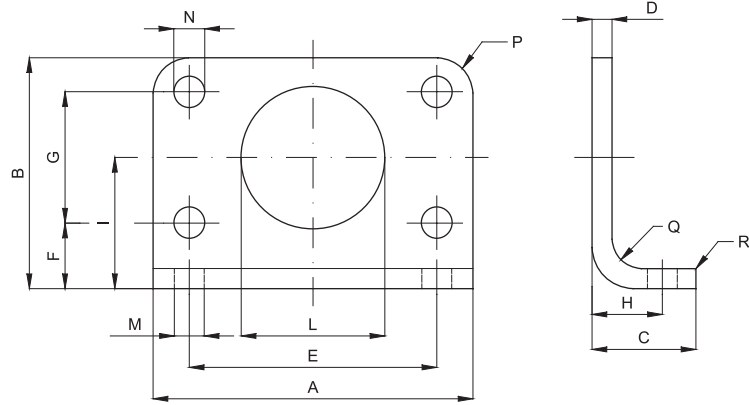

Material: Zinc plated steel

Code	Item	Ø mm	A	B	C	D	E	F	G	H	I	L	M	N	P	Q	R
040054	P32AQM	32	66	49	21	4	52	14	28	14	28	30	7	7	7	4	2
040055	P40AQM	40	80	58	30	5	60	18	30	20	33	38	9	9	10	5	2
040056	P50AQM	50	90	70	30	6	70	20	40	20	40	45	9	9	10	6	2

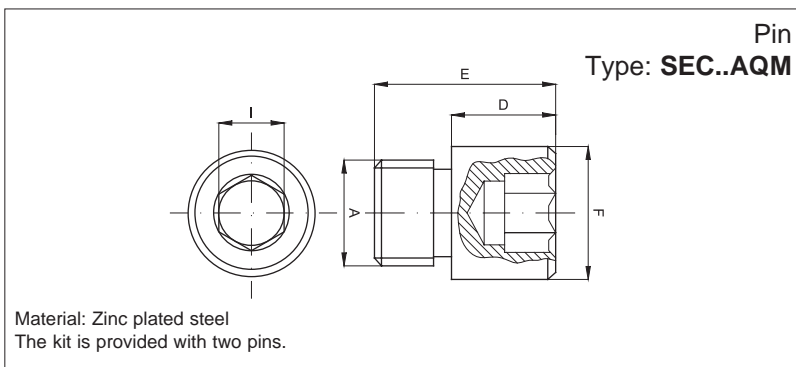

Material: Zinc plated steel
The kit is provided with two pins.

Code	Item	Ø mm	A	D	E	F	I
040062	SEC32AQM	32	M8x1	8	14	Ø 10	5
040063	SEC40AQM	40	M10x1	9,5	15,5	Ø 12	6
040064	SEC50AQM	50	M12x1,5	11	20	Ø 14	6